



**IN-WALL® SLIDE-OUT
OWNER'S MANUAL**

LIPPERT
COMPONENTS®

TABLE OF CONTENTS

Safety Information	3
Operation	3
Prior To Operation	3
Extending Slide-Out Room	4
Retracting Slide-Out Room	4
Controller Overview (B Version)	5
Controller Overview (C2 Version)	6
Motor and Controller Compatibility	7
Rewiring Instructions	8
Motors and Harnesses	9
Resynchronizing the Slide-Out Motors	9
Extend and Retract Switch Connections	9
Power and Ground Connections At the Controller	9
Troubleshooting	10
Checking Circuit Breakers	10
Obstructions	10
Debris In the Rack	10
Error Codes	10
Electronic Manual Override (Controllers C-1, C-2 and D-0 Only)	11
Motor Disengagement Procedure	11
Low Voltage	11
Motor Direction Switches	11
Custom	12
In-Wall® Slide-Out Repair Kit	12
In-Wall® Slide-Out Assembly	13
In-Wall® Slide-Out Controllers	14
In-Wall® Slide-Out Motors	15
In-Wall® Slide-Out Components	16
In-Wall® Slide-Out Components	17
In-Wall® Slide-Out Components	18
In-Wall® Slide-Out Components	19

Safety Information

WARNING

Failure to act in accordance with the following may result in death, serious injury, coach or property damage.

The IN-WALL® Slide-out System is intended for the sole purpose of extending and retracting the slide-out room. Its function should not be used for any purpose or reason other than to actuate the slide-out room. To use the system for any reason other than what it is designed for may result in death, serious injury or damage to the coach.

Before actuating the system, please keep these things in mind:

1. Parking locations should be clear of obstructions that may cause damage when the slide-out room is actuated.
2. Be sure all persons are clear of the coach prior to the slide-out room actuation.
3. Keep hands and other body parts away from slide-out mechanisms during actuation.
4. To optimize slide-out actuation, park coach on solid and level ground.

Operation

Prior To Operation

1. Coach should be parked on the most level surface available.
2. Leveling or stabilizing system should be actuated to ensure coach will not move during operation of slide-out system.

NOTE: In the case of a motorized unit, ignition **MUST** be off to operate the slide-out.

3. Be sure to keep all persons and pets clear of slide-out system during operation.

NOTE: Install transit bars (if so equipped) on the slide-out room during storage and transportation.

CAUTION

Always make sure that the slide-out room path is clear of people and objects before and during operation of the slide-out. Always keep away from the gear racks when the room is being operated.

Extending Slide-Out Room

1. Level the unit.

NOTE: In the case of a motorized unit, ignition **MUST** be off to operate the slide-out.

2. Remove the transit bars (if so equipped).
3. Press and hold the IN/OUT switch (Fig. 1B) in the OUT position until the room is fully extended and stops moving.

NOTE: It is important to continue to press the slide-out switch for a few seconds after the room is fully extended until the motor shuts off. The control will sense that the room has stopped and will shut off the motor after a few seconds.

4. Release the switch, which will lock the room into position.

Retracting Slide-Out Room

NOTE: In the case of a motorized unit, ignition **MUST** be off to operate the slide-out.

5. Press and hold the IN/OUT switch (Fig. 1A) in the IN position until the room is fully retracted and stops moving.

NOTE: It is important to continue to press the slide-out switch for a few seconds after the room is fully retracted until the motor shuts off. The control will sense that the room has stopped and will shut off the motor after a few seconds.

6. Release the switch, which will lock the room into position.
7. Install the transit bars (if so equipped).

Fig. 1

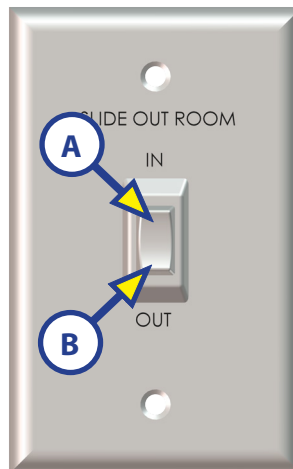

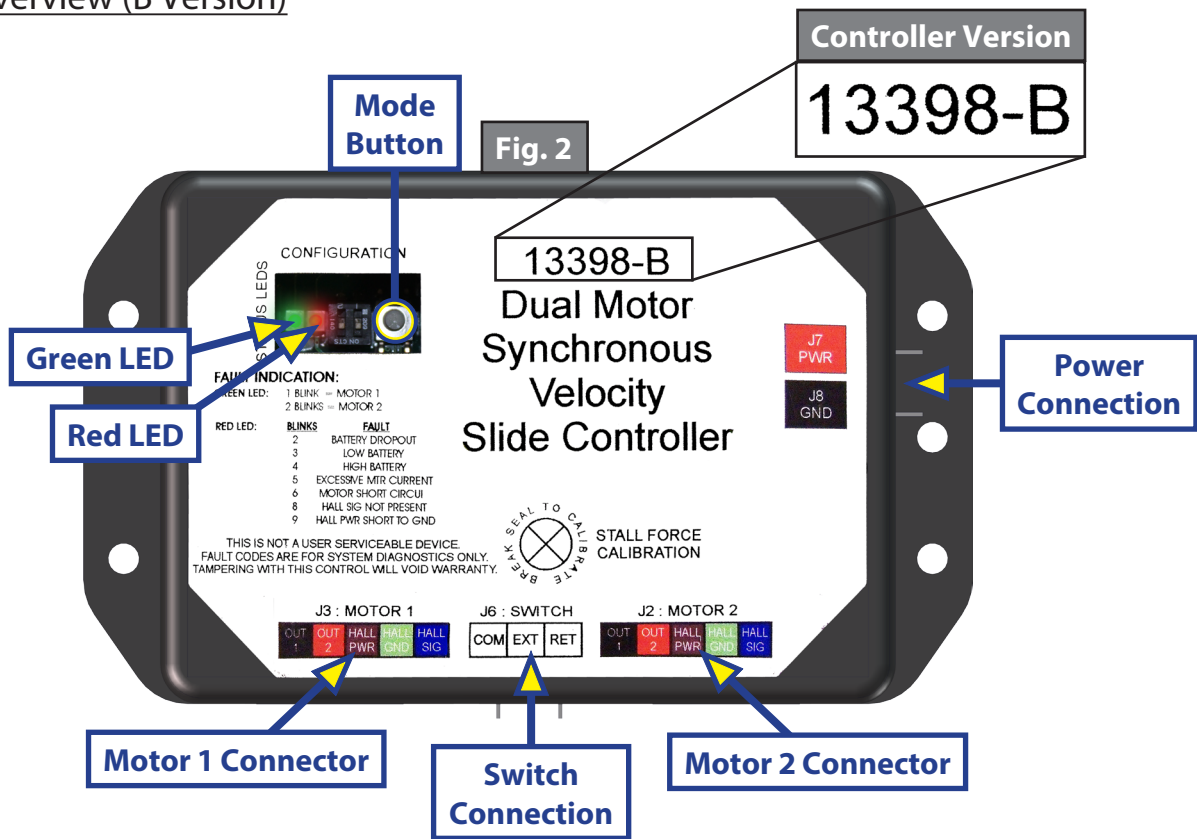

Fig. 3 - Controller Connections

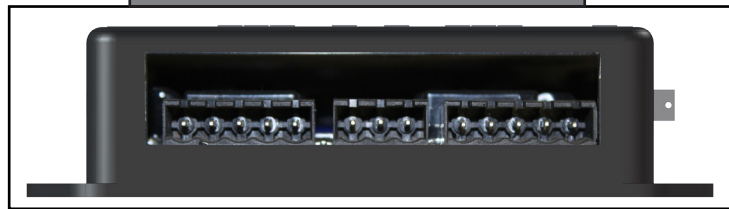
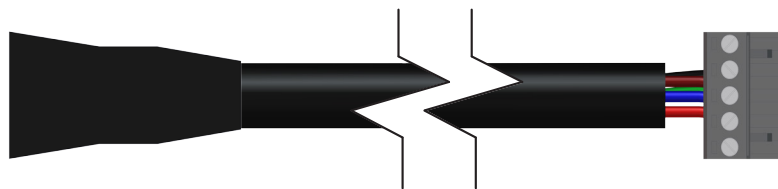

Fig. 4 - Motor Harness



Status LEDs: 2 LEDs, 1 green and 1 red, are provided to indicate current controller status and faults.

Power Connection: 12V DC input. Unit will operate from 8V DC to 18V DC.

Switch Connection: Spade connection for the switch wiring.

Motor 1 Connector: Power and encoder input for motor 1.

Motor 2 Connector: Power and encoder input for motor 2.

NOTE: Version B motor harnesses have five wire in-line connectors at the controller and the molded connector at the motor end (Figs. 3 and 4). Wire colors match with color codes on control board. It does not matter which motor is 1 or 2.

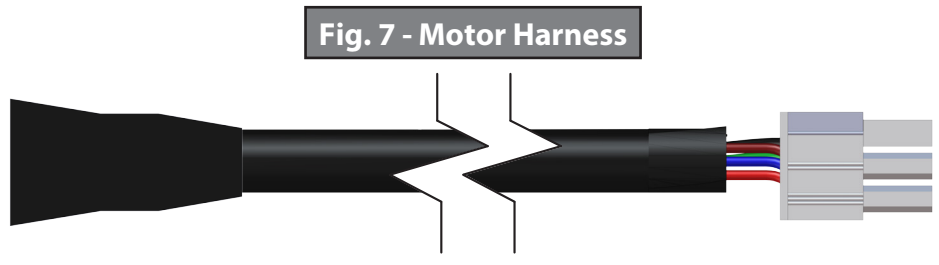
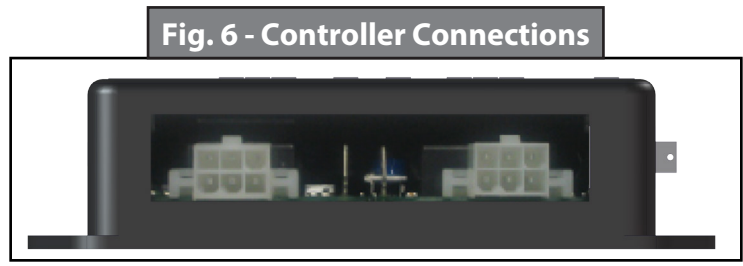
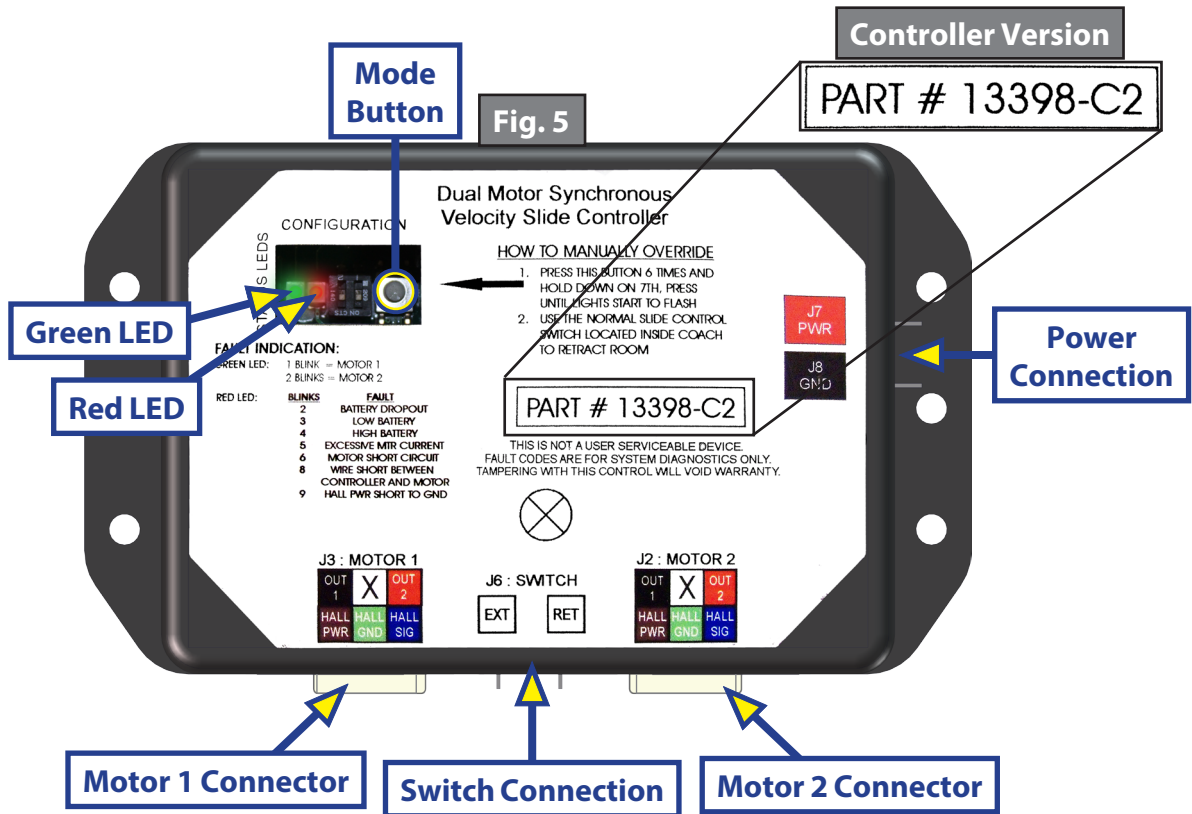

Status LEDs: 2 LEDs, 1 green and 1 red, are provided to indicate current controller status and faults.

Mode Button: Used to engage the electronic manual override.

Power Connection: 12V DC input. Unit will operate from 8V DC to 18V DC.

Switch Connection: Spade connection for the switch wiring.

Motor 1 Connector: Power and encoder input for motor 1.

Motor 2 Connector: Power and encoder input for motor 2.

NOTE: Motor harnesses have Molex® connectors at the controller and a molded connector at the motor end (Figs. 6 and 7). Wire colors match with color codes on control board. It does not matter which motor is 1 or 2.

Motor and Controller Compatibility

Part #	Controller Version	Controller Replacement	Motor(s) Used
239657	A (Daisy Chain) (Fig. 8)	A Only	Round-Square (Fig. 14), Round-Round (Fig. 15A)
211852	B (Fig. 9)	B/C2* Only	Round Square (Fig. 14)
	C (Fig. 10)	C/C2* Only	Round-Round (Fig. 15A, 15B), Round-Square Plate (Fig. 16)
	C1 (Fig.11)	C1/C2* Only	
	C2 (Fig. 12)	C2	
326876	8 Amp (Fig. 13)	8 Amp Only	Round-Round (Fig.15B)

NOTE: Always replace the motor in the system with the same motor except the Round-Square Plate (Fig. 16), which is obsolete. That motor will be replaced with the Round-Round (Fig. 15A, 15B).

NOTE: (*) Denotes that (2) new motor harnesses **MUST** be ordered, and re-wiring instructions **MUST** be used. See next page.

Fig. 8

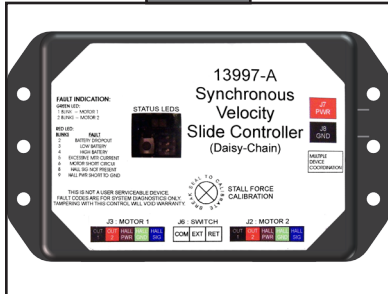

Fig. 9

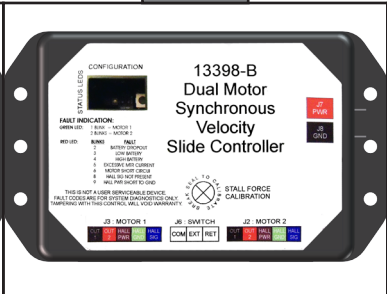

Fig. 10

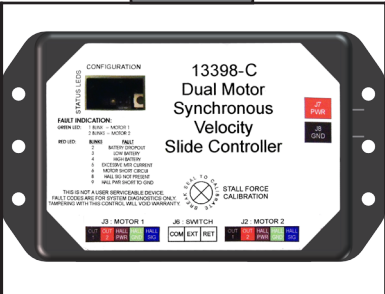

Fig. 11

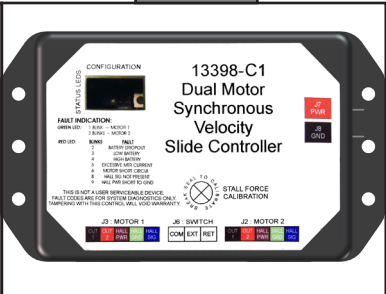

Fig. 12

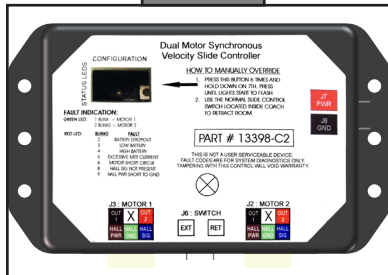

Fig. 13

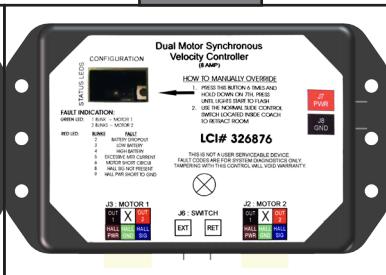

Fig. 14 - 229466



Fig. 15A - 236575, 300:1



Fig. 15B - 287298, 500:1



Fig. 16 - Obsolete



NOTE: Ensure that a 300:1 motor is replaced with a 300:1 motor (Fig. 15A), and that a 500:1 motor is replaced with a 500:1 motor (Fig. 15B).

Rewiring Instructions

If it is necessary to replace a malfunctioning Rev. B, C, or C1 controller, it is recommended that the customer do so with a new Rev. C2 controller. In order to properly rewire a Rev. B, C, or C1 controller to a new Rev. C2 controller, the customer will need two new motor harnesses (one for each motor.) Additionally, it will be necessary to modify the power wire from the controller to the extend/retract switch by adapting the wire to piggyback the connection at the power junction. This wire comes from the positive side of the buss bar to the controller (Fig. 17).

Fig. 17

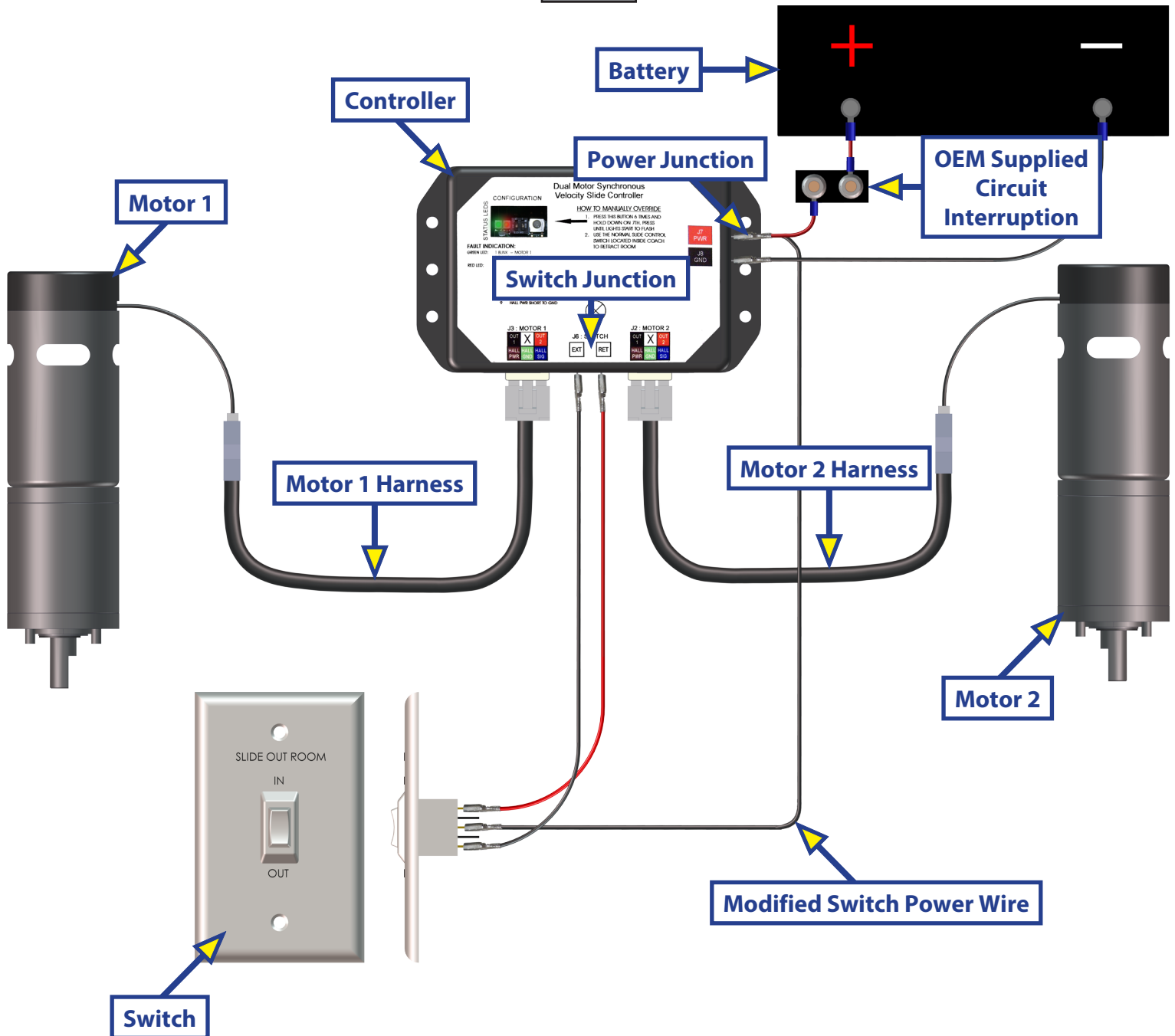

Motors and Harnesses

1. Check for proper connections between the motors and harnesses (Fig. 18).
2. Visually inspect the exposed harnesses to ensure they are not pinched or damaged.

NOTE: Ribs on motor connector line up with notch inside of female connector on wiring harness. Color codes on wires also match (black to black, red to red, etc.)

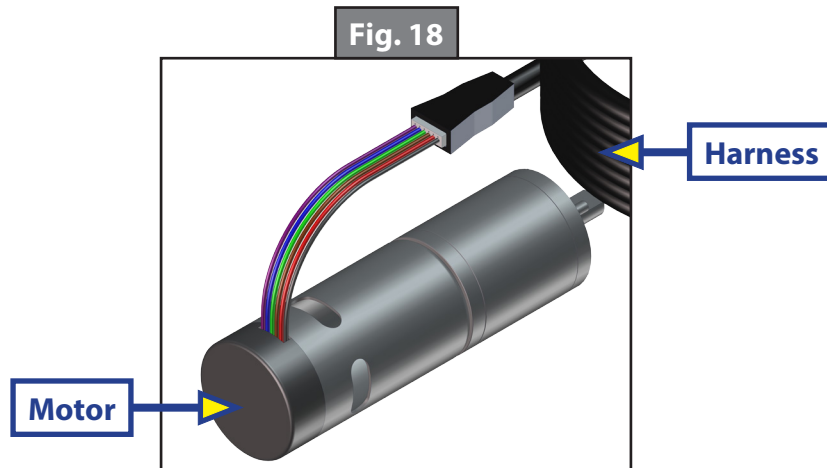

Resynchronizing the Slide-Out Motors

1. Fully extend the slide room using the switch. Keep the switch engaged until the motors shut down on their own.
2. Retract the room 1-2 inches.
3. Repeat steps 1 and 2 until both motors shut down at the same time. In many cases, two or three repetitions are necessary to re-sync the system.
4. Fully extend the slide-out and keep the switch engaged until the motors shut down on their own. Fully retract the slide-out, again keeping the switch engaged until the motors shut down on their own. If both motors shut down at the same time at full extension and full retraction, the room is properly synchronized. If they do not shut down at the same time, repeat the process until they do.

Extend and Retract Switch Connections

Rev. A - Rev. C1 Controllers: Common connection on controller goes to common connection on extend and retract switch.

Rev. C2 and 8 amp Controllers: Extend and retract connections on the controller go to the extend and retract terminals on the switch. Switch is powered by the OEM supplied 12V DC power source.

Power and Ground Connections At the Controller

Power and ground are supplied to the controller through the spade terminals located on the right-hand side of the controller (Figs. 2 and 5 - Power Connection). 12V DC is recommended. A 10ga wire is the minimum size recommended. A 30 amp resetting or blade fuse is required (OEM supplied).

Troubleshooting

Checking Circuit Breakers

The IN-WALL® Slide-out requires a minimum of a 30-amp circuit breaker. Check the 12-volt circuit breaker box for blown circuit breakers, and replace any if necessary. Consult the RV manufacturer's documentation for the location of the 12-volt circuit breaker box, and the location of the IN-WALL® Slide-out controller's circuit breaker. If the circuit breaker blows immediately upon replacement, there is a problem with the wiring to the IN-WALL® Slide-out controller. Have qualified service personnel check and repair.

Obstructions

Check outside the RV for possible obstructions: tree, post, car, etc. Check inside the RV for any obstructions: luggage, furniture, open cabinets, etc. Also, check for smaller objects that may be wedged under the floor or in the sides of unit. Remove obstructions before proceeding.

Debris In the Rack

Check the sides of the slide room for any dirt or debris. Small dirt clumps or metal shavings can cause the spur gear to bind up and stop the movement of the slide-out. Use compressed air or a dry brush to remove any dirt or debris from the rack before attempting to actuate the system again.

Error Codes

During operation when an error occurs, the board will use the LEDs to indicate where the problem exists (Fig. 19). For motor-specific faults the green LED will blink 1 time for motor 1, and 2 times for motor 2. The red LED will blink from 2 to 9 times depending on the error code (Fig. 20).

When an error code is present, the board needs to be reset. Energizing the extend/retract switch (Fig. 1) resets the board. Energize the extend/retract switch again for normal operation.

Fig. 19

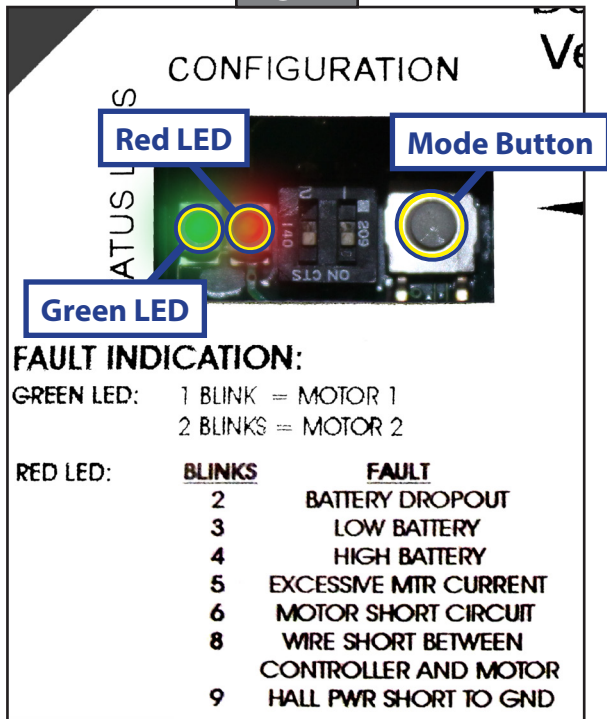

Fig. 20 - Error Code Descriptions

Error Code	Name	Description
2	Battery Drop Out	Battery capacity low enough to drop below 6 volts while running or short in switch wiring.
3	Low Battery	Voltage below 8 volts at start of cycle.
4	High Battery	Voltage greater than 18 volts.
5	Excessive Motor Current	High amperage, also indicated by 1 side of slide continually stalling.
6	Motor Short Circuit	Motor or wiring to motor has shorted out.
8	Wire Short Between Controller and Motor	Encoder is not providing a signal. This is usually a wiring problem.
9	Hall Power Short To Ground	Power to encoder has been shorted to ground. This is usually a wiring problem.

Electronic Manual Override (Controllers C-1, C-2 and D-0 Only)

NOTE: See (Fig. 21) for locations of the mode button and LEDs.

1. Press the mode button on the controller six times and hold on the seventh for five seconds to enter electronic manual override mode.
2. Use the extend/retract switch to move both motors in or out.

NOTE: Over-current and short circuit detection are still enabled. Electronic manual override provides 12V directly to both motors.

3. To exit the mode, push and hold the mode button until the LEDs begin to blink simultaneously. Exiting the override mode resets the motor positions (you will have to resync motors).

NOTE: During this override procedure the motors are not synchronized. Visually watch the room: if one side is moving significantly slower than the other (or not at all) then immediately stop and use the "Motor Disengagement Procedure" below.

Motor Disengagement Procedure

1. Remove motor retention screws located near the top of each vertical column on the outside of the coach (under bulb seal if equipped with bulb seal on column).
2. Locate motor.
 - A. On units built prior to 2011: Bend back wipe seal from outside of coach.
 - B. On units from 2011 to current: See slot in H-column on the inside of the coach.
3. Pull motor up until disengaged (roughly 1/2"). A flat-head screwdriver can be used to pry the motor up.
4. Reinstall motor retention screw to hold motor in place or remove motor.

Low Voltage

The Lippert IN-WALL® Slide-out Controller is capable of operating the room with as little as 8 volts. But at these lower voltages the amperage requirement is greater. Check voltage at the controller, see Figs. 2 and 5 for the location of power connections. If the battery is low, it needs to be charged or the unit should be plugged into shore power or the generator can be run, if equipped. It may be possible to "jump" the RV's battery temporarily to extend or retract the room. Consult the RV manufacturer's owners manual.

NOTE: Always connect directly to the battery and never to the controller power connections.

Motor Direction Switches

Motor direction switches (Fig. 21) are used to change the direction of individual motors. If when trying to extend or retract the room, one side goes in and the other side goes out, then there is a problem in the wiring. The motor direction switches can be used to correct this problem. The left switch controls motor 2 and the right switch controls motor 1. If motor 1 is going in the wrong direction then change switch 1's position. If motor 2 is going in the wrong direction then change switch 2's position.

The motor direction switches can also be used to change the direction of the extend/retract switch. If the room extends when the extend/retract switch is moved to the retract position, its direction can be reversed by moving both switch 1 and switch 2 to their opposite positions. This feature can be used if it is more convenient to change the motor direction switches than to rewire the extend/retract switch.

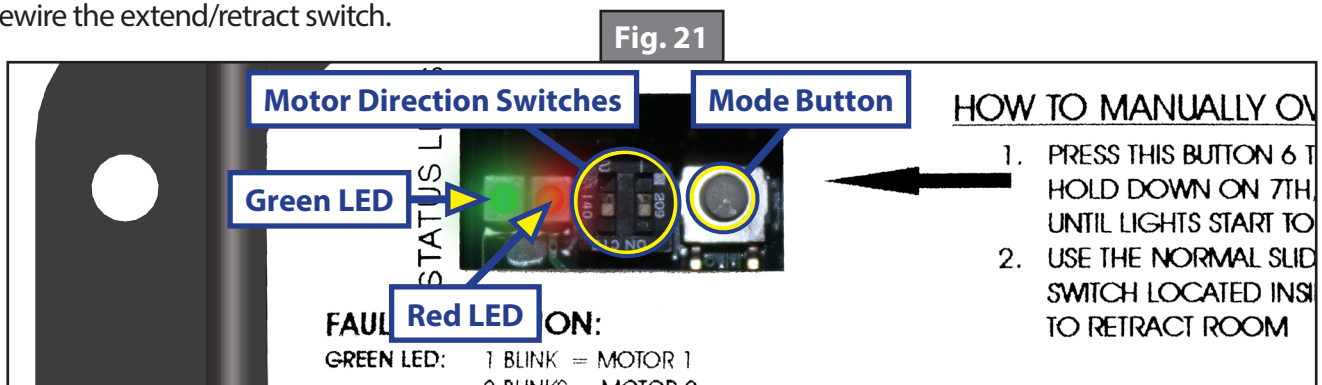

SLIDE-OUTS

Custom

If the system being repaired has a different notch than the 1.56" described on the previous page, use the images below to identify the notch, then contact LCI Parts at (574) 537-8900 for ordering assistance.

NOTE: If the gear rack being replaced has notches on both ends, the rack will need to be custom ordered. Contact LCI Parts at (574) 537-8900 for ordering assistance.

Custom Kit Numbers	
Kit #	Description
366121	Standard (without gear racks)
366120	Inverted (without gear racks)
366106	Triple (without gear racks)

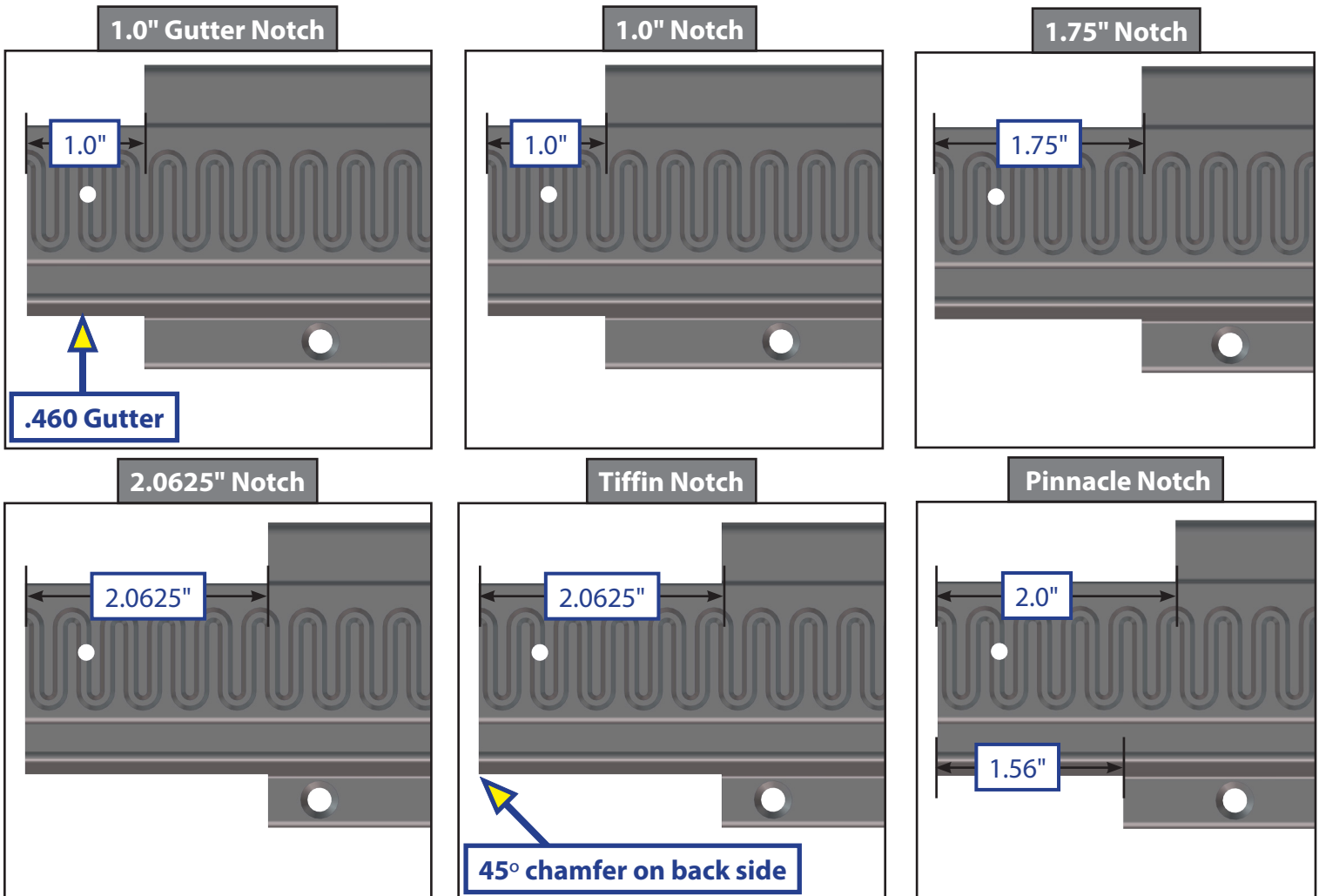



LIPPERT
COMPONENTS

IN-WALL® SLIDE-OUT ASSEMBLY

SLIDE-OUTS

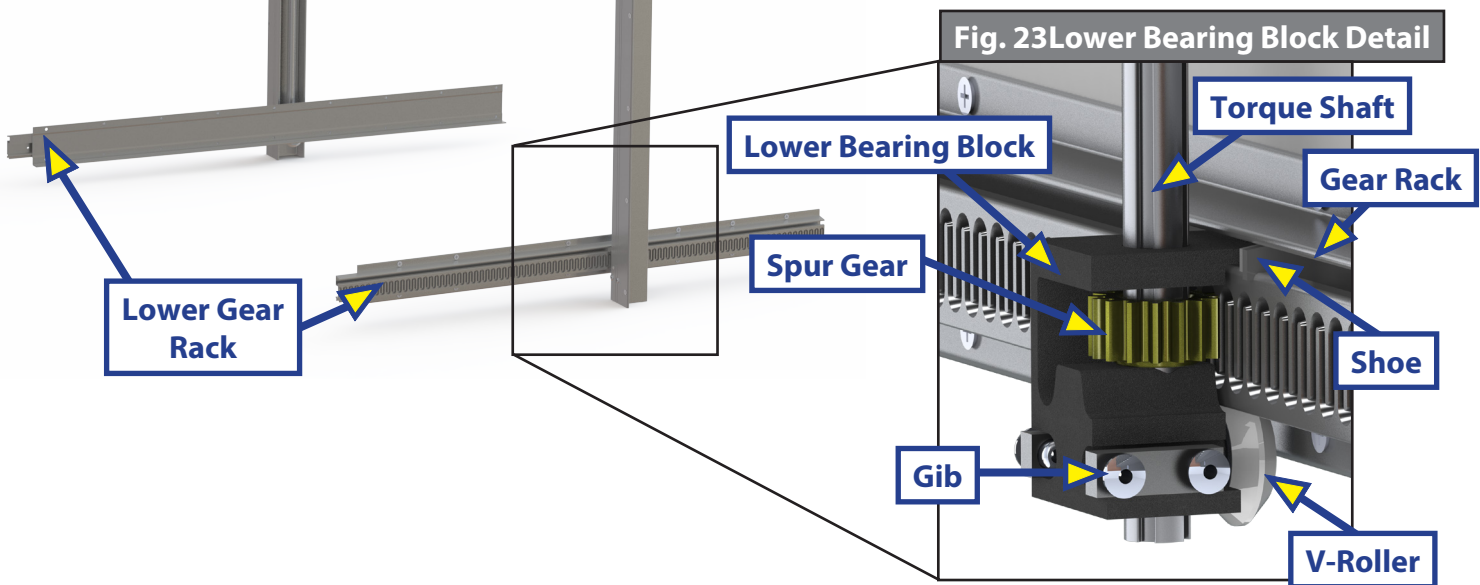
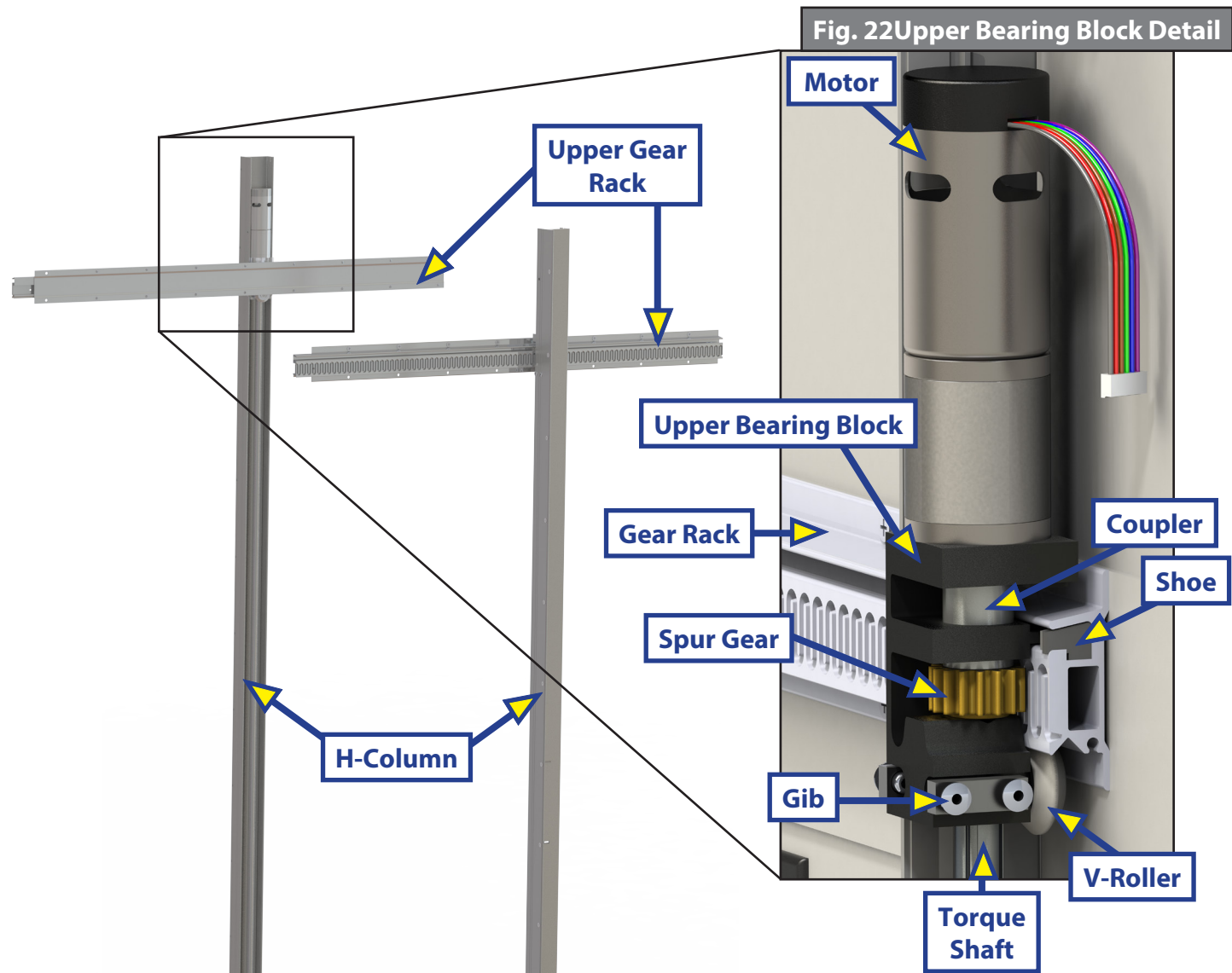

Contact us: Lippert Components Inc. - www.lci1.com/support - Phone: (574) 537-8900 - Email: customerservice@lci1.com



IN-WALL® SLIDE-OUT CONTROLLERS

SLIDE-OUTS

Rev B

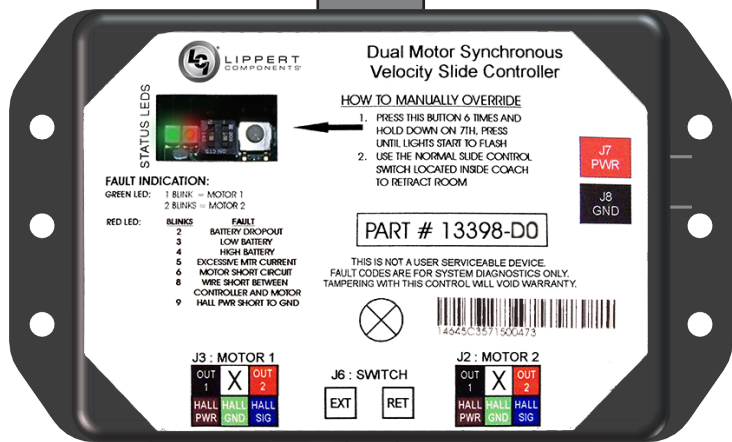

Rev C-1

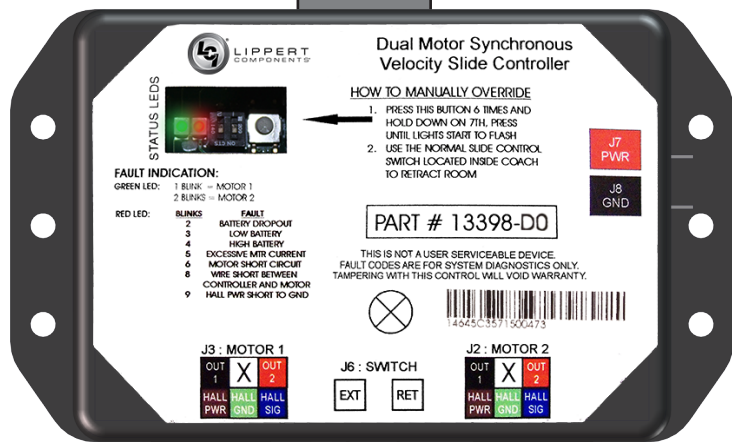

Rev C-2

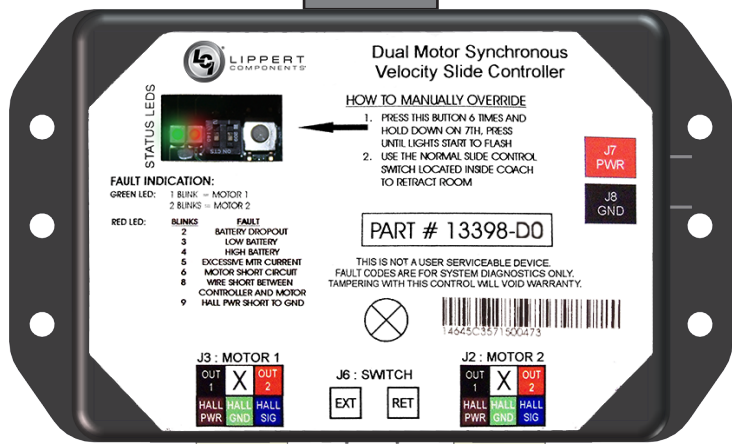

8 Amp

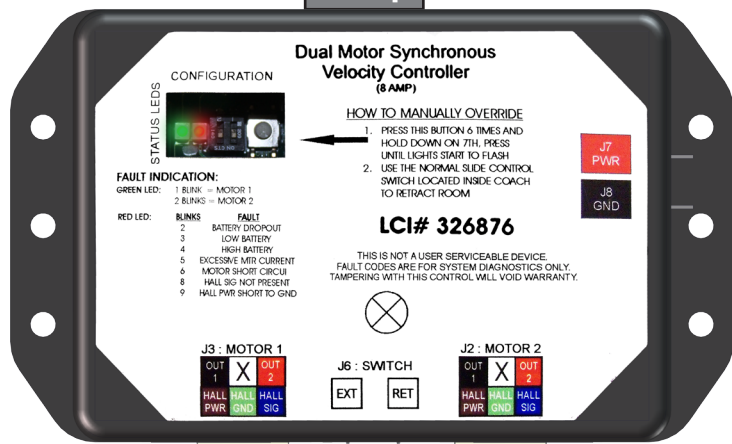

Part #	Description
211852 - Rev B, Rev C-1, Rev C-2	Dual Motor Synchronous Velocity Slide Controller
326876 - 8 amp	Dual Motor Synchronous Velocity Slide Controller NOTE: This controller will not replace other controller versions.

SLIDE-OUTS



Callout	Part #	Description
A	229466	Motor, 300:1 (Cannot be substituted for Callout C)
B	236575	Motor, 300:1 Obsolete (Replace with Callout C)
C	236575	Motor, 300:1
D	287298	Motor, High Torque 500:1



IN-WALL® SLIDE-OUT COMPONENTS

SLIDE-OUTS

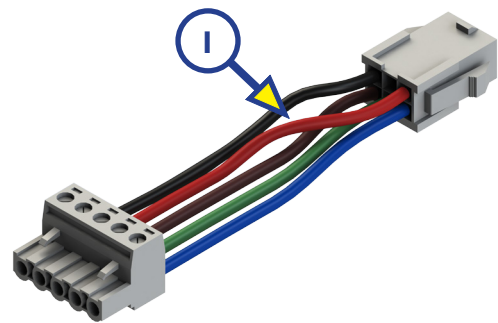
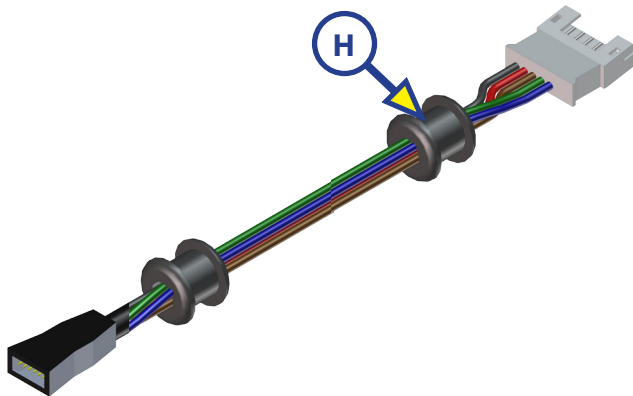
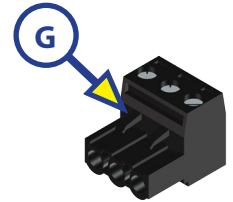
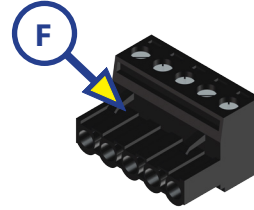
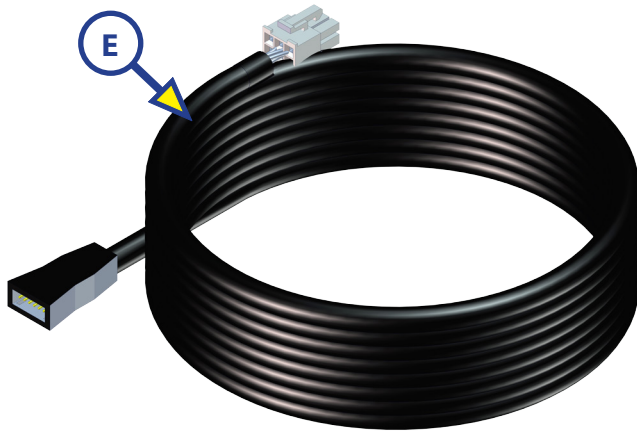

Callout	Part #	Description
E	238744	5 ft. Controller to Motor Harness
	238990	10 ft. Controller to Motor Harness
	247768	15 ft. Controller to Motor Harness
	229755	20 ft. Controller to Motor Harness
	238991	25 ft. Controller to Motor Harness
	229756	30 ft. Controller to Motor Harness
	238992	35 ft. Controller to Motor Harness
F	229758	Harness Connectors 5 Wires
G	229759	Harness Connectors 3 Wires
H	241834	5 ft. Interconnect Harness
	241835	6 ft. Interconnect Harness
	241836	8 ft. Interconnect Harness
I	258760	Slide Controller 6" Pigtail Harness (For use with B and C-1 Controllers with (A) harness)



LIPPERT
COMPONENTS

IN-WALL® SLIDE-OUT COMPONENTS

SLIDE-OUTS

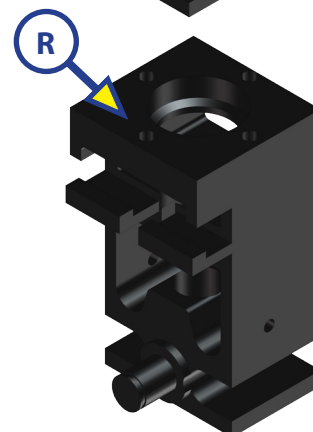
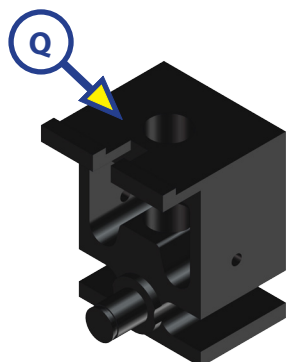
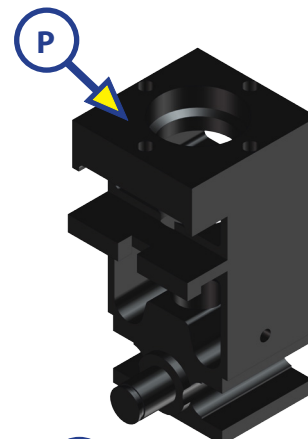
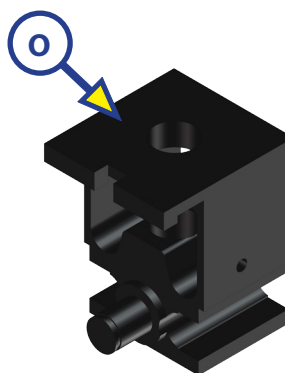
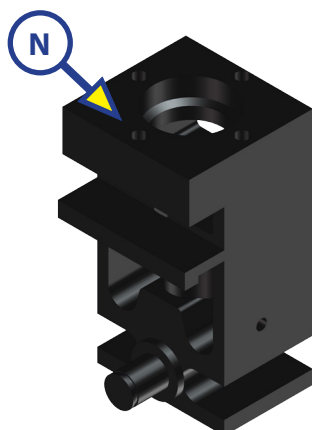
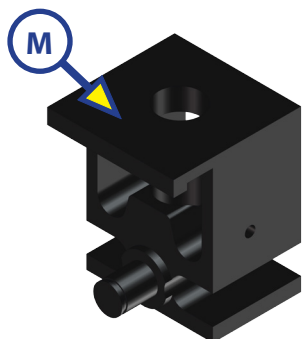
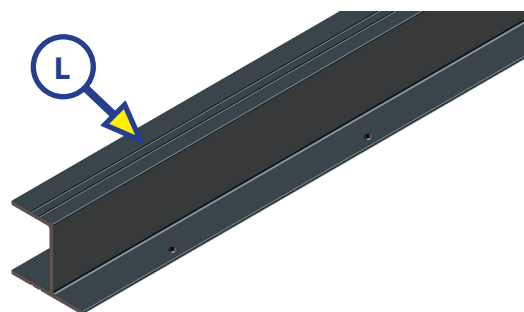
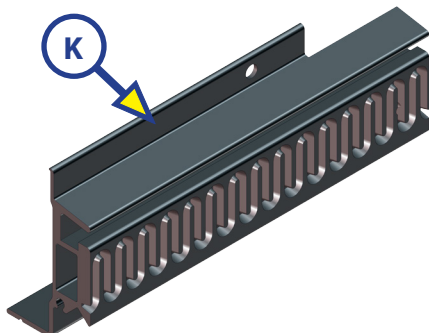
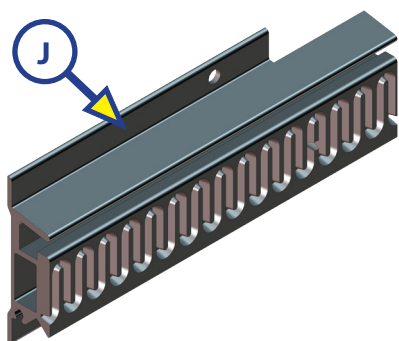

Callout	Part #	Description
J	*See Note	Upper Gear Rack
K	*See Note	Lower Gear Rack
L	*See Note	H-Column, Black
	*See Note	H-Column, White
M	*See Note	Lower Bearing Block
N	*See Note	Upper Bearing Block
O	*See Note	Lower Bearing Block (Hex Shaft)
P	*See Note	Upper Bearing Block (Hex Shaft)
Q	*See Note	Lower Bearing Block (Steel Shaft)
R	*See Note	Upper Bearing Block (Steel Shaft)
NOTE: *Parts shown for reference only. The part is not available for individual replacement.		

Contact us: Lippert Components Inc. - www.lci1.com/support - Phone: (574) 537-8900 - Email: customerservice@lci1.com

SLIDE-OUTS

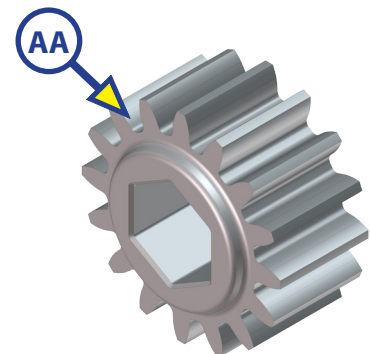
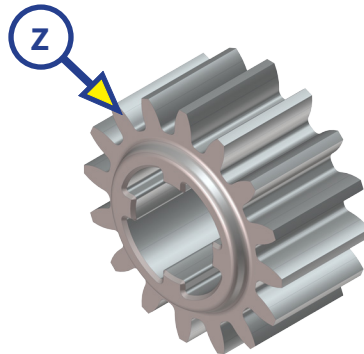
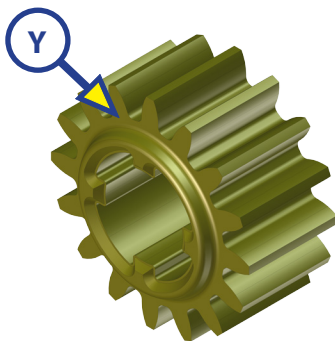
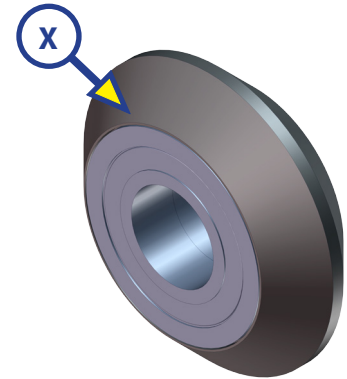
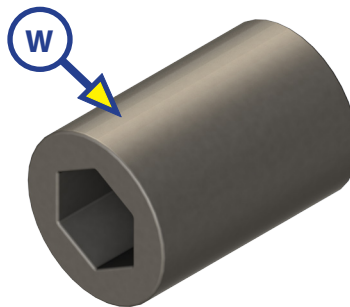
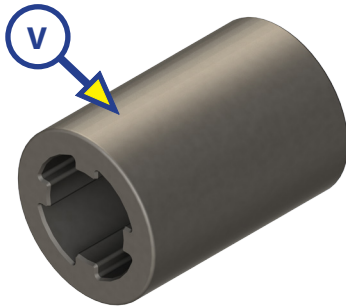
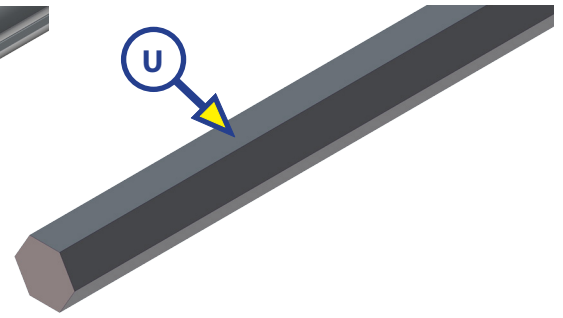
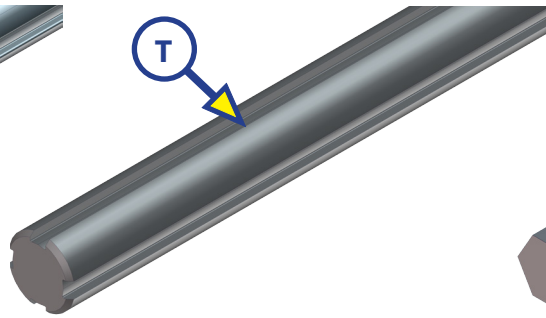
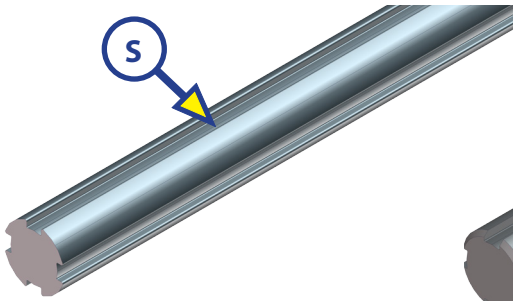

Callout	Part #	Description
S	*See Note	Aluminum Torque Shaft
T	*See Note	Steel Torque Shaft
U	*See Note	Hex Torque Shaft
V	238461	Coupler - Old Style (for 229466 Motor)
	238461	Coupler - New Style (for 236575 Motor)
W	285083	Hex Coupler
X	*See Note	V-Roller Assembly
Y	*See Note	Spur Gear
Z	*See Note	Copper Infused Spur Gear
AA	*See Note	Hex Spur Gear
NOTE: *Parts shown for reference only. The part is not available for individual replacement.		

SLIDE-OUTS

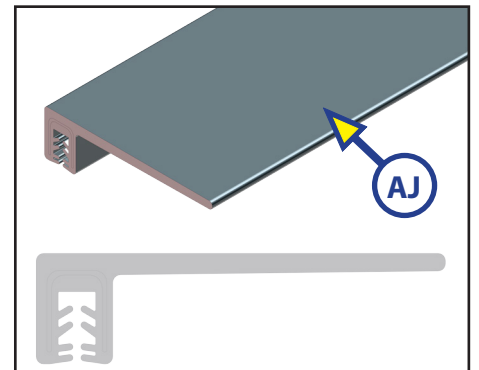
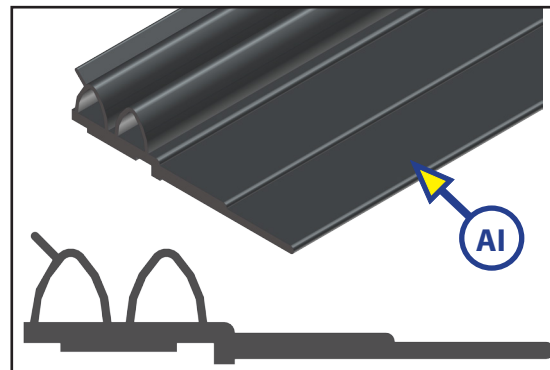
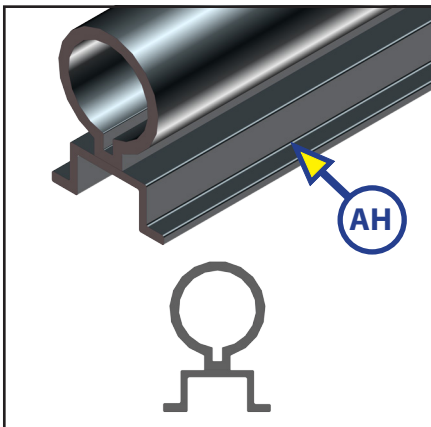
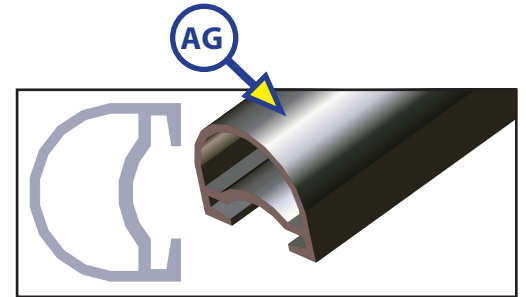
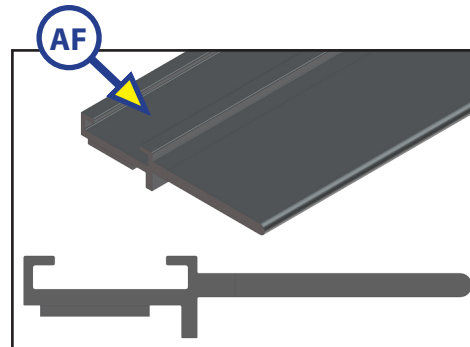
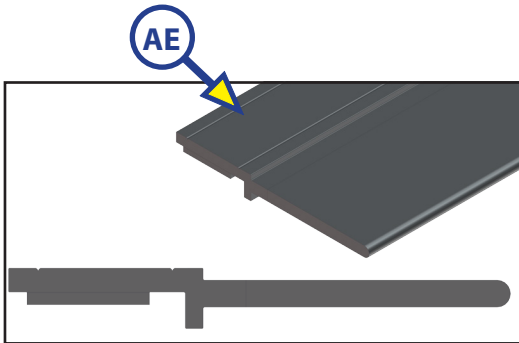
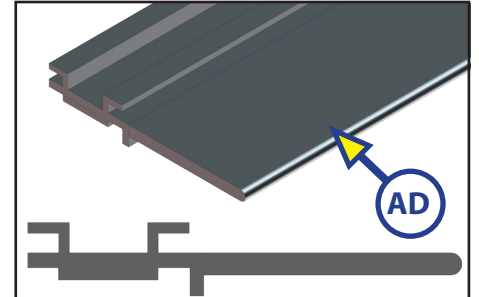
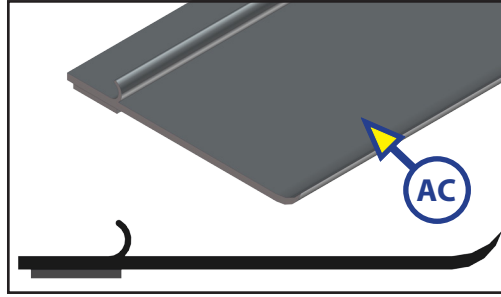
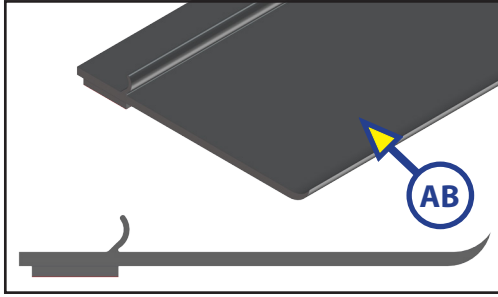

Callout	Part #	Description	Measurements
AB	156603	Seal	1" x 2 21/32" x 5/64"
AC	132733	Sweep Seal	2 43/64" x 1/16"
AD	239667	EK Design Flap	1 1/4"
AE	240410	Flat Side Wiper	1 1/4"
AF	240448	KE Black Single Wiper with Leg	1 1/4"
AG	260406	EK Black Slide on D-Seal	-
AH	240449	KE Black Slide on Bulb Seal	-
AI	253344	Winnebago Double Bulb Seal	-
AJ	300614	Slide-out Seal	144"



L I P P E R T C O M P O N E N T S®

The contents of this manual are proprietary and copyright protected by Lippert Components, Inc. ("LCI"). LCI prohibits the copying or dissemination of portions of this manual unless prior written consent from an authorized LCI representative has been provided. Any unauthorized use shall void any applicable warranty. The information contained in this manual is subject to change without notice and at the sole discretion of LCI.

Revised editions are available for free download from www.lci1.com.

Please recycle all obsolete materials.

For all concerns or questions, please contact
Lippert Components, Inc.

Ph: (574) 537-8900 | Web: lci1.com | Email: customerservice@lci1.com